

SIGN	R E V I S I O N	DATE	B Y
△	Correct a Direction	950720	M.T

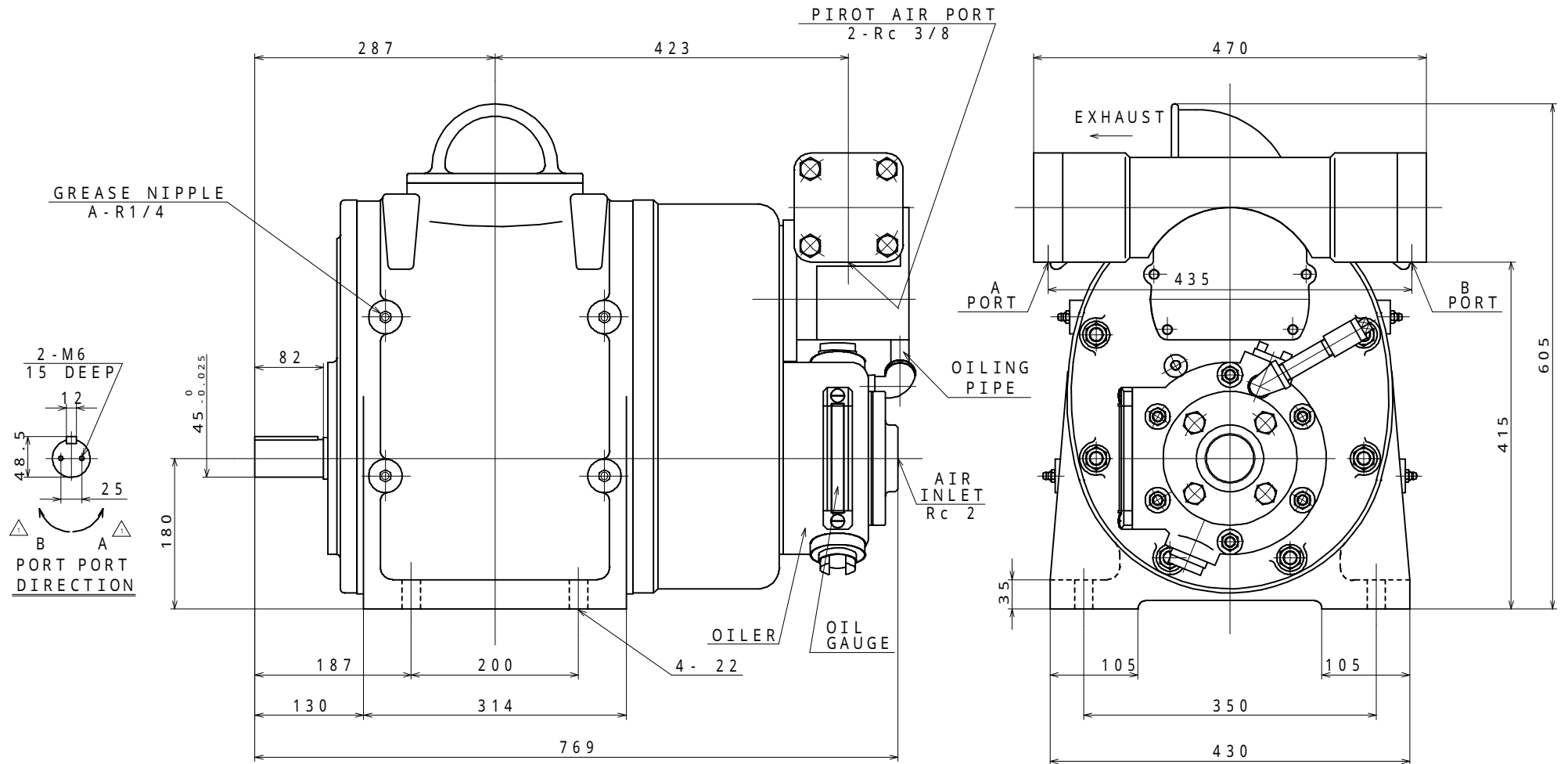

SPECIFICATION

AIR PRESSURE	AT MAXIMUM OUTPUT				OILER QUANTITY	OIL CONSUMPTION	LUBRICATING OIL		MASS
	OUTPUT	SPEED	TORQUE	AIR CONSUMPTION			OILER	GREASE NIPPLE	
(MPa)	(kW)	(rpm)	(N·m)	(Nm ³ /min)	(cc)	(cc/hr)	JIS K2213-2 Turbine Oil ISO VG32-56	JIS K2220 4-2 Lithium Grease	(kg)
0.6	22.5	1500	143	25.5	1800	180~230			About 370
0.5	18.7		119	21.0					
0.4	14.9		95	17.0					

APPROVED	CHECKED	REVIEWED	DRAWN	PARTICULARS	OUTLINE DRAWING	DATE	NOV.19.1997
S.N		M.M	S.O	MODEL	AGM23-HBR1	NOTE	
					AIR MOTOR	Z97-023	
SAN-EI SEIKI SEISAKUSHO CO.,LTD.					DWG. NO.	E397-304	SCALE